

Product information

UP-DO Pump Series

Normal priming, centrifugal pumps
with a double mechanical seal
material: stainless steel 1.4581

SCHMITT

chemical resistant pumps

Description

UP-DO Pump Series



SCHMITT

chemical resistant pumps

Normal priming centrifugal pumps with a double Mechanical seal

Application: The UP-Do Pump Series is designed for all sorts of applications and is perfectly suitable for the transmitting operation in stainless steel plants as well as for severe thermal stress environments.

Field of application: Circulation pump for heat exchanger, use for very hot alkaline liquids, laboratory applications, environment engineering, paper manufacturing, electroplating technology, airplane jet engine cleaning plants, filtration, food industry, varnish processing operations, for soiled and metallically contaminated media

Materials: Stainless steel 1.4581

Completely dry run safe with connected seal water circle

Max. output rate: 460 l/min

Max. discharge head: 39 m

Motor power: 0,18 - 5,5 kW

In the UP-Do Pump Series, the motor power is transmitted without slip directly to the pump impeller with a rigid shaft (no magnetic coupling). A double mechanical seal (back to back) prevents the leakage of the media to be pumped and ensures the leak proof sealing of the centrifugal pump. All parts that are in contact with the medium are made solid of stainless steel (1.4581). The cooling and lubrication of the mechanical seals is carried out through a separate seal water circle.

Advantages:

- » with a connected seal water circle, the pump cannot be damaged, neither through operator error or malfunctions in the plant (dry run safe under certain conditions).
- » applicable for media without lubricating properties (e.g. varnishes and paints)
- » also applicable for higher viscosities or metallic particles in the medium
- » the highest chemical resistance also at high temperatures up to +150° C
- » robust, thick-walled design, solid stainless steel fine cast (no thin-walled extruded sheet metal)
- » low-maintenance through an optimal adaptation to the medium to be pumped
- » long-lasting and wear resistant, various types of designs for almost all operating conditions
- » open impeller (i.e. solids up to 3 mm grain size and 10 Vol. % possible)
- » easy to maintain (wear parts and the mechanical seal can be changed swiftly)
- » universally applicable, quiet and compact
- » various chemical resistant materials can be supplied as stock items

Types

UP-DO Pump Series

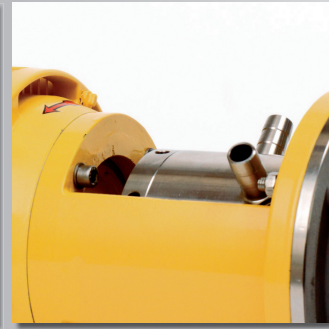

SCHMITT

chemical resistant pumps

- Materials and Components:**
- » Main material: Parts solid made of stainless steel 1.4581
 - » Elastomere alternatively made of FKM, EPDM, FEP or Kalrez®
 - » Shaft made of stainless steel
 - » Mechanical seals made of PTFE, ceramic, carbon or SiC
 - » The double mechanical seal is spring-loaded (spring made of Hastelloy C4)
 - » High-quality electric motors made in Germany

- Materials details:**
- » **Stainless steel:** 1.4571 or stainless steel fine cast 1.4581 (A4), up to +150° C
 - » **FKM:** Viton® quality, -20...+200° C
 - » **EPDM:** Ethylene propylene diene M-class rubber, Food-safe (FDA, KTW, WRC), -40...+160° C
 - » **FEP:** Fluorinated ethylene propylene with Viton® or silicone core, -60...+200° C
 - » **Kalrez®:** High performance elastomere up to +315° C
 - » **PTFE:** Pure Teflon®, fiber glass or carbon fiber reinforced
 - » **SiC:** Silicon carbide, without free silicon, sintered
 - » **Carbon:** Carbon, impregnated with synthetic resin, food-safe
 - » **Hastelloy C4:** 2.4610
 - » **Ceramic:** highly pure Al₂O₃ - ceramic 99,7%

Types

UP-DO Pump Series

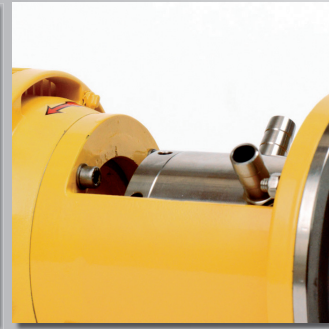

SCHMITT

chemical resistant pumps

Motor details:

- Standard Motors (stock items):
- » Three-phase motors: 230/400 V 3ph, 50 Hz, IP 55, insulation-class F
 - » or 277/480 V 60 Hz also with PTC thermistor
 - » Alternating current motors: 230 V 1ph, 50/60 Hz, IP 55, Insulation class F
 - » Three-phase motors: spark arrested for combustible environments, explosion proof: EEx e IIT3

- Special design models (available):
- » Three-phase motors, explosion proof, flameproof enclosure, EEx de II CT4
 - » Special voltages and frequencies
 - » 2-, 4- and 8-pole
 - » UL and CSA execution
 - » Special protection types (e.g. IP 65)
 - » High temperature designs
 - » Special insulation classes (e.g. tropical insulations)
 - » Multi area voltage (e.g. 220-290 / 380-500 V 50 Hz; 220-332 / 380-575 V 60 Hz.)
 - » Additional designs upon enquiry.

Characteristics

UP-DO Pump Series

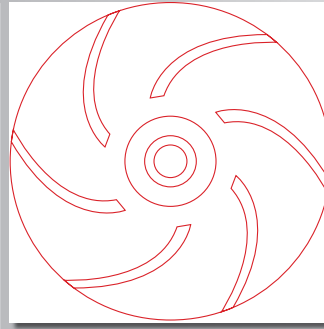

SCHMITT

chemical resistant pumps

UP-DO 100 to UP-DO 210 Pump Series

- Motor power**
- » UP-DO 210: 5,50 kW
 - » UP-DO 190: 3,00 kW
 - » UP-DO 170: 2,20 kW
 - » UP-DO 150: 1,10 kW
 - » UP-DO 130: 0,55 kW
 - » UP-DO 115: 0,25 kW
 - » UP-DO 100: 0,18 kW

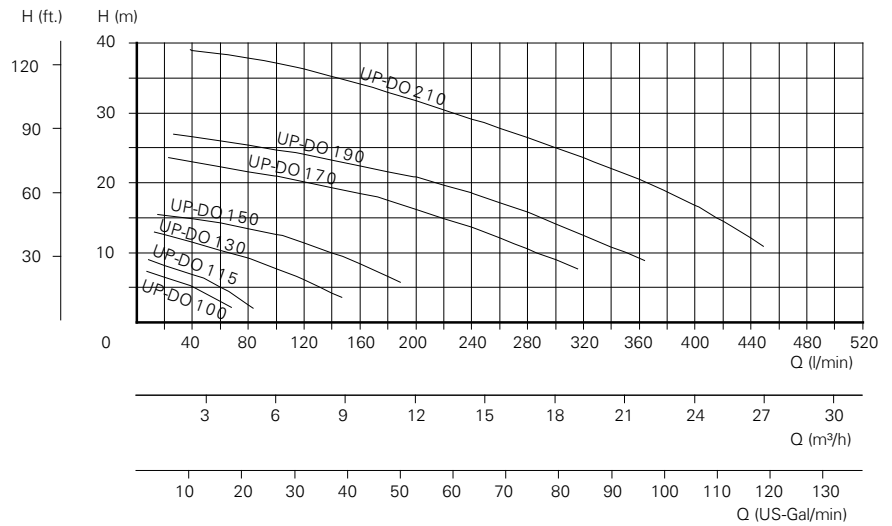

Characteristic lines measured with water, 20° C and 2900 Rpm (50 Hz.)

Parts Descriptions

UP-DO Pump Series

chemical resistant pumps

Design C

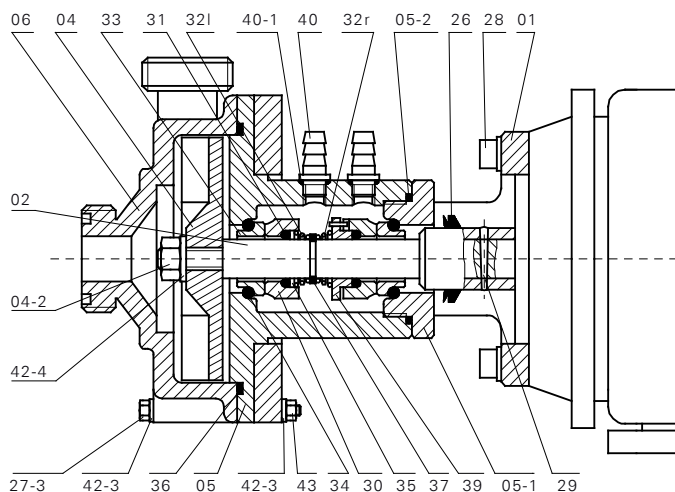

Part-No.	Part	Materials standard	on request
01	mounting flange	aluminium	
02	shaft extension	1.4571	
04	impeller	1.4581	
04-2	locking nut	1.4571	
05	backplate	1.4571	
05-1	inset	1.4571	
05-2	O-Ring	Viton	
06	pump housing	1.4581	
26	flinging disc	rubber	
27-3	hexagon bolt	A4	
28	bolt + washer	A4	
29	cotter pin	1.4305	
30	rotating seal	carbon	SiC
31	o-ring seal	Viton®	FEP or EPDM
32	coil spring	Hastelloy C	
33	stationary seal	ceramic	SiC
34	o-ring seal	Viton®	FEP or EPDM
35	thrust washer	1.4571	
36	pump housing seal	Viton	FEP or EPDM
37	lockwasher	A4	
39	spacer ring	1.4305	
40	hose nozzle	1.4305	
40-1	O-Ring	Viton®	
42-3	washer	A4	
42-4	locking washer	A4	
43	hexagon nut	A4	

Seal water - wiring diagram UP-DO Pump Series

For pumps with double
mechanical seal

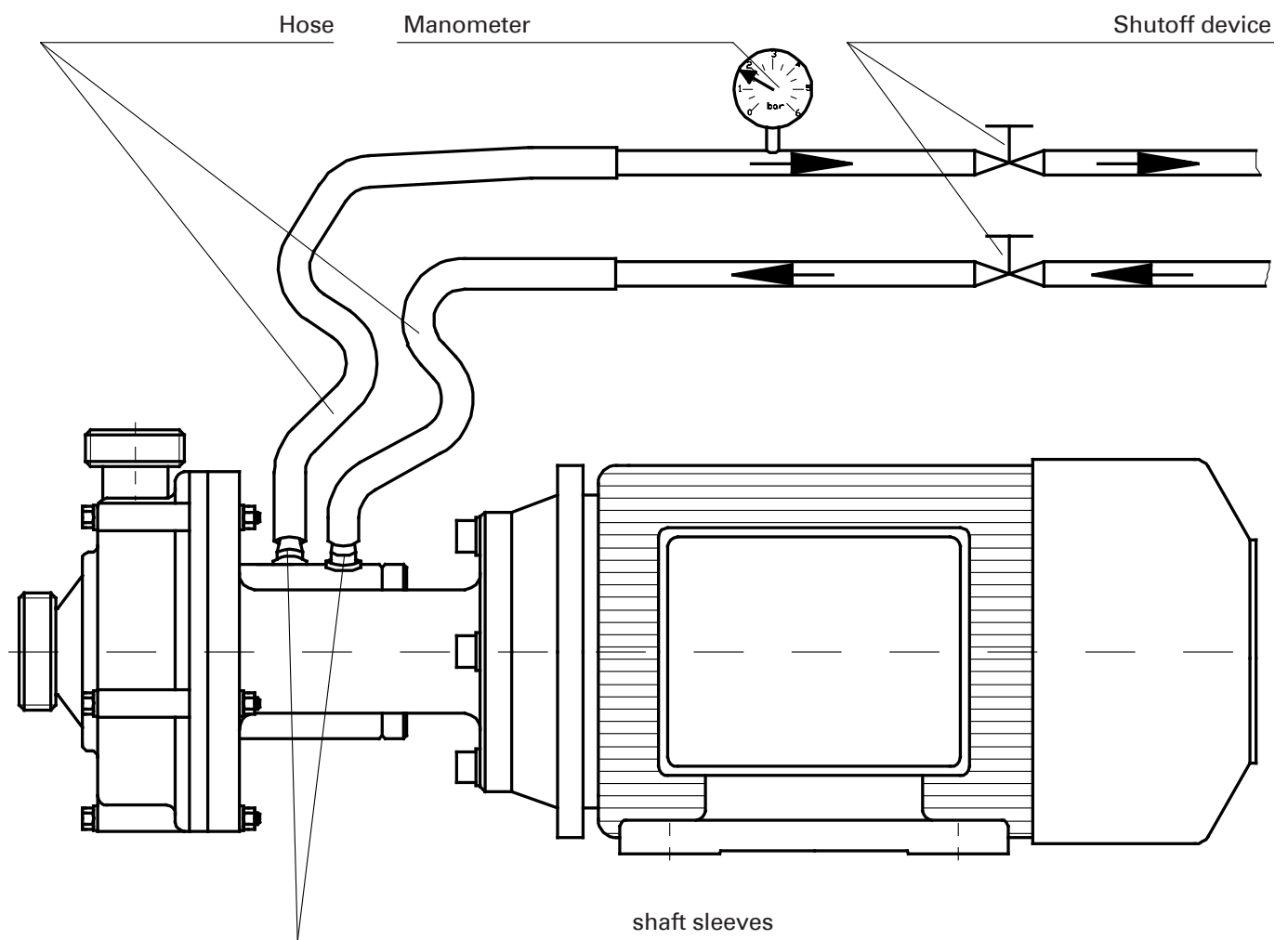

The necessary barrier pressure can be determined after following rules:

$$P_{\text{sperr}} \text{ (bar)} = H/20 \times \rho + 1 \text{ to } 1,5 \text{ bar}$$

ρ (kg/dm³) = specific gravity of the medium to be pumped

H = max. discharge head

Specification

UP-DO Pump Series

chemical resistant pumps

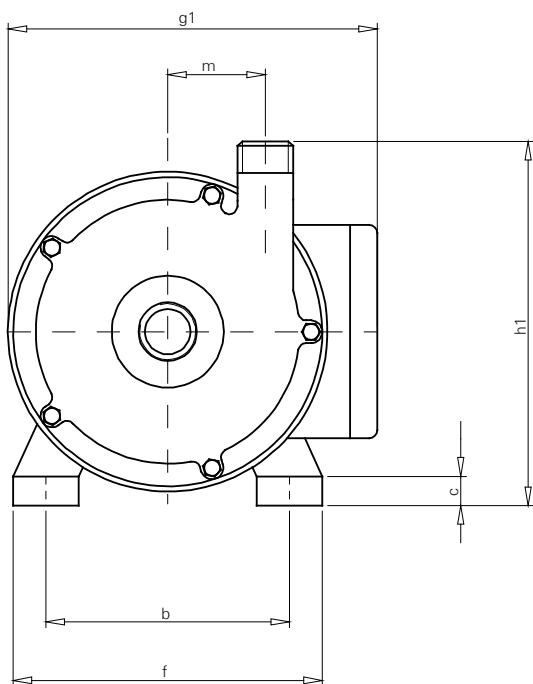

Type	h	p	g	a	e	ø s	b	f	c	g1	ø z	l	l1	l2	m	h1	suction conn.		pressure conn.		weights kg
																	nom. bore	male thread	nom. bore	male thread	
UP-DO 100	56	112	111	71	90	6	90	110	9	146	13	321	146	187	35	126	15	G¾"	15	G¾"	6,7
UP-DO 115	63	125	123	80	100	7	100	125	10	158	13	367	171	216	35	140	15	G¾"	15	G¾"	8,0
UP-DO 130	71	140	139	90	108	8	112	140	11	182	13	393	177	222	42	157	20	G1"	20	G1"	13,0
UP-DO 150	80	157	154	100	125	10	125	160	11	187	13	436	200	251	47	176	25	G1½"	20	G1"	18,7
UP-DO 170	90	180	177	125	152	11	140	180	14	240	13	520	242	301	55	200	32	G1½"	25	G1¼"	28,0
UP-DO 190	100	197	194	140	170	12	160	200	15	258	13	548	249	308	60	220	32	G1½"	25	G1¼"	39,0
UP-DO 210	112	260	224	140	180	12	190	235	16	296	13	575	256	320	70	242	40	G2"	32	G1½"	61,0

The dimensions of the motors refer to three-phase standard motors.

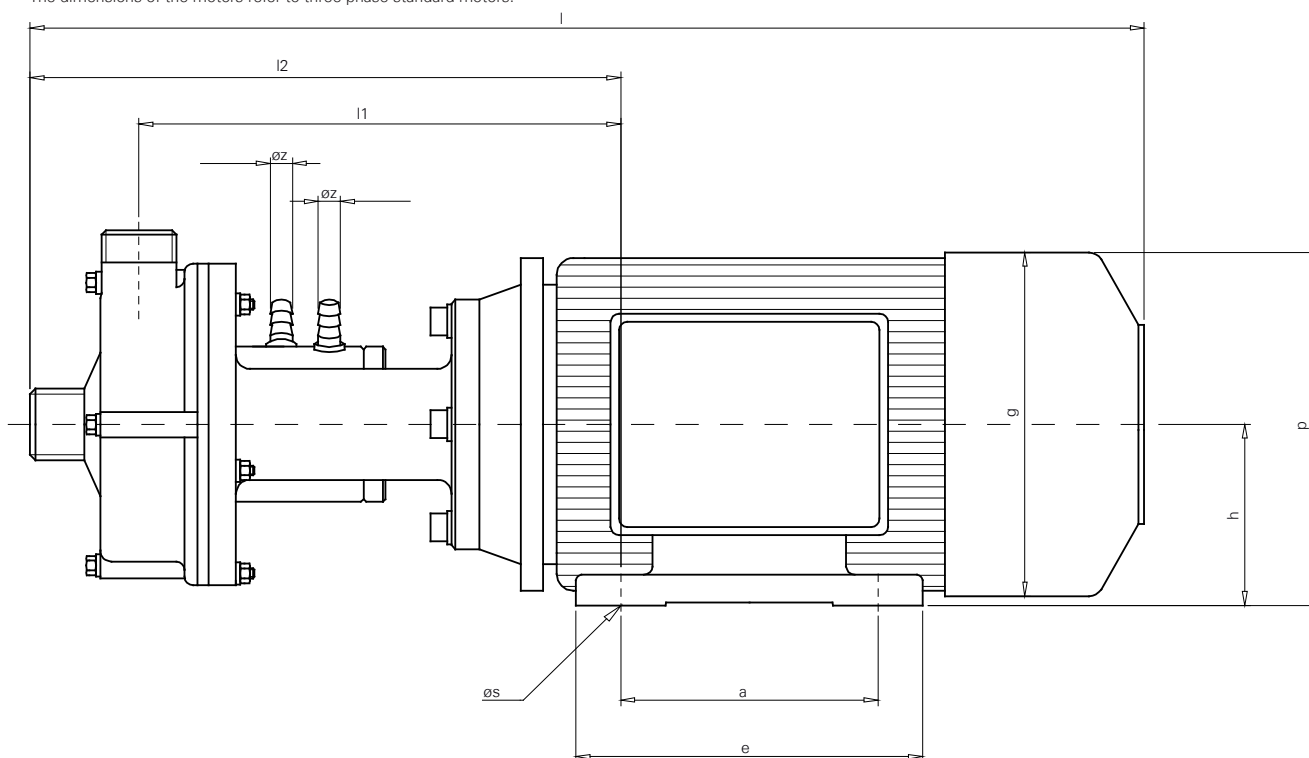

Types

UP-DO Pump Series

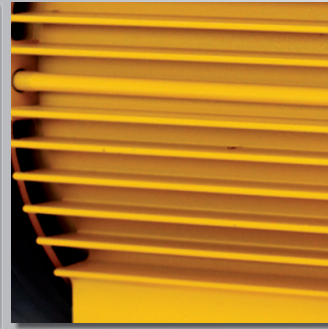

SCHMITT

chemical resistant pumps

Motors:

- » all driving motors are to IEC standard operating on 230/400 volts 50 cycles.
- » single phase A.C. motors are also available up to 1,10 kW.
- » explosionproof motors can be supplied to the whole range of pumps.
- » special voltages, frequencies and types of protection can be delivered on request.

Note:

- » upon request all motors can be supplied for USA standard (UL proof).
- » for each pump also detail handouts are available.

SCHMITT

Kreiselpumpen GmbH & Co.KG

Einsteinstrasse 33

D - 76275 Ettlingen, Germany

Phone: +49 - 72 43 - 54 53 - 0

Fax: +49 - 72 43 - 54 53 - 22

info@schmitt-pumpen.de

www.schmitt-pumpen.de



We reserve the right to alter the technical details.
Dimensions and performance details without guarantee.

updated 03/2013